

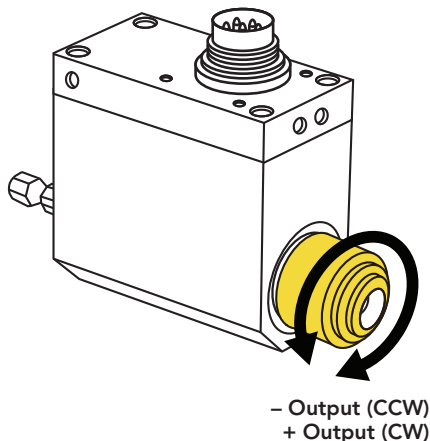

FEATURES

- Utilizes strain gauge technology
- Compact size
- Can operate up to 3000 RPM
- Slip ring assembly

Active end



SPECIFICATIONS

PERFORMANCE

Nonlinearity	±0.2% of RO
Hysteresis	±0.1% of RO
Nonrepeatability	±0.2% of RO
Rotational Speed	3000 RPM Max

ELECTRICAL

Rated Output (RO)	1 mV/V nom (2 Nm); 2 mV/V nom (6–20 Nm)
Excitation (VDC or VAC)	5 to 11
Connection	6 pin Binder Series #581 (09-0323-99-06)

MECHANICAL

Weight (approximate)	0.7 lb [0.30 kg]
Safe Overload	150% of RO
Material	Aluminum (Housing) Steel Alloy (Shaft)
IP Rating	IP40

TEMPERATURE

Operating Temperature	14 to 194°F (–10 to 90°C)
Compensated Temperature	41 to 122°F (5 to 50°C)
Temperature Shift Zero	±0.01% of RO/°F (±0.02% of RO/°C)
Temperature Shift Span	±0.01% of Load/°F (±0.02% of Load/°C)

CALIBRATION

Calibration Test Excitation	10 VDC
Calibration (standard)	Certificate of Conformance
Calibration (available)	5-pt CW & CCW
Shunt Calibration Value (Internal)	87 kOhm (2 Nm), 43 kOhm (6–20 Nm)
Shunt Calibration	With sensor fully connected jump Pins 1 & 6 to generate full mV/V output

CONFORMITY

RoHS	2014/30/EU
CE	Declaration of Conformity

DIMENSIONS inches [mm]

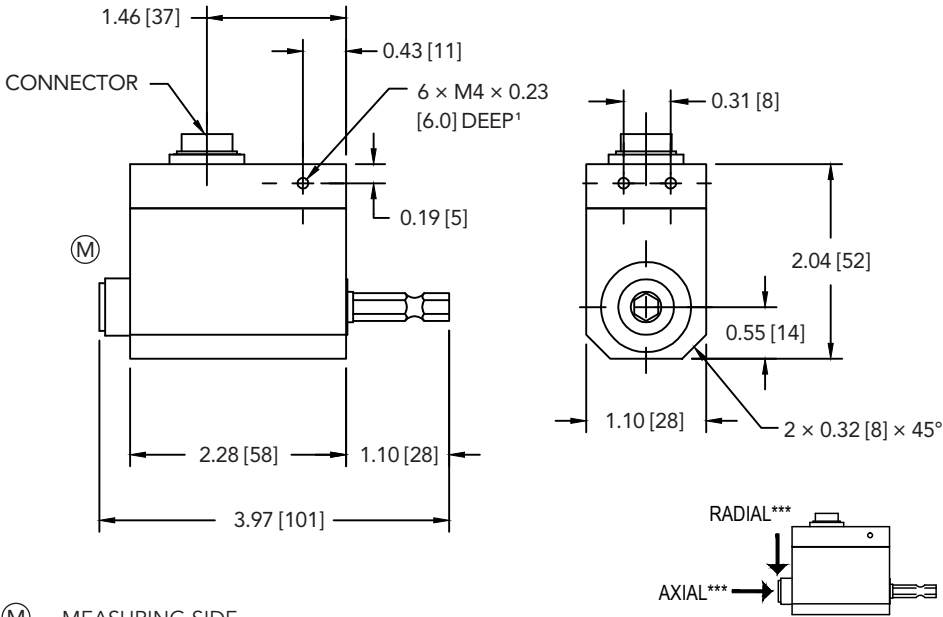

(M) = MEASURING SIDE.

TORQUE SENSOR WITH STANDARD 1/4" HEX PER DIN 3126 E & F
 * ANTI-ROTATION HOLES, NOT TO BE USED TO SUPPORT LOAD
 ** MAXIMUM LOAD ALLOWED, NOT FOR MEASUREMENT

CONNECTOR CODES

PIN	COLOR	DESCRIPTION
1	Black	- Excitation
2	Red	+ Excitation
3	Floating	Shield
4	Green	+ Signal
5	White	- Signal
6	Orange	Shunt Cal

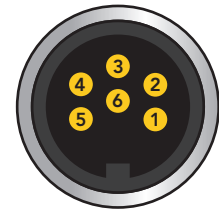

CAPACITIES

ITEM #	in-lb	Nm	*** Max Axial Force lb [N]	*** Max Radial Force lb [N]
FSH01979	18	2	4.5 [20]	4.5 [20]
FSH01980	53	6	11.3 [50]	9 [40]
FSH01981	106	12	11.3 [50]	9 [40]
FSH01982	177	20	33.7 [150]	9 [40]

Drawing Number: FI1403

FUTEK reserves the right to modify its design and specifications without notice.
 Please visit <http://www.futek.com/salesterms> for complete terms and conditions.

10 Thomas, Irvine, CA 92618 USA

Tel: (949) 465-0900
 Fax: (949) 465-0905

www.futek.com



RoHS



U.S. Manufacturer